

Assembly Instruction POWERTEX Lifting Sling Components Grade 10

Temperature range: -40°C up to +200°C (without WLL reduction)

WLL chart for POWERTEX Chain Slings Grade 10

Chain	Single		2-leg*		3-4-leg*		Endless		
Ø									
mm	Straight	Choke	Basket	0°-45°	45°-60°	0°-45°	45°-60°	Choke	Basket
6	1,4	1,12	2,8	2	1,4	3	2,12	2,24	5,6
7	1,9	1,5	3,8	2,65	1,9	4	2,8	3	7,6
8	2,5	2	5	3,55	2,5	5,3	3,75	4	10
10	4	3,15	8	5,6	4	8,4	6	6,3	16
13	6,7	5,3	13,4	9,5	6,7	14	10	10,6	26,8
16	10	8	20	14	10	21,2	15	16	40
19	14	11,2	28	20	14	30	21,2	22,4	56
20	16	12,8	32	22,4	16	33,6	24	25,6	64
22	19	15	38	26,6	19	40	28	30	76
26	26,5	21,2	53	37,5	26,5	56	40	42,5	106
32	40	31,5	80	56	40	85	60	64	160
Factor (K _L)	1	0,8	2	1,4	1	2,1	1,5	1,6	4

* When using multi-leg sling in choke lift - reduce the value by 20%.

Assembly clevis component / chain

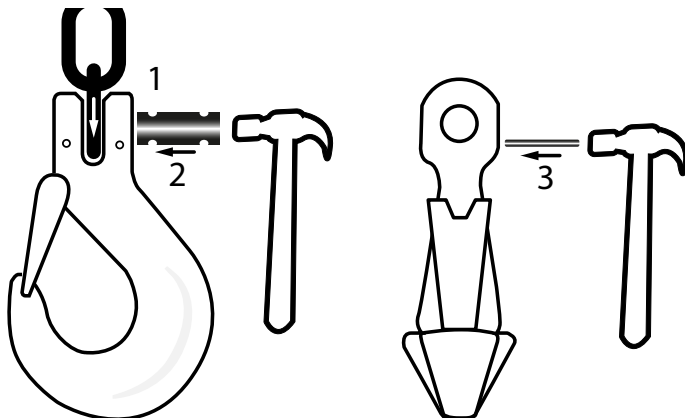

Assembly connecting link / chain, component

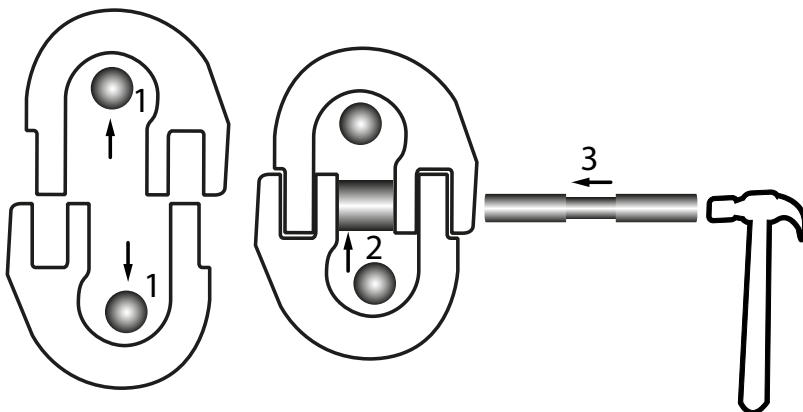

User Manual for chain slings can be found at www.powertex-products.com