

Lever Hoist POWERTEX PLH-S2OLP with electrogalvanized chain

Product information



The Powertex PLH-S2 OLP Chain Hoist is a high-quality lever hoist designed to provide durability, safety, and ease of operation. With its ergonomic ratchet lever, safety-added features, and built-in overload protection, this chain hoist ensures smooth and efficient lifting for various industrial applications. This OLP version has an integrated Overload Protection, which ensures safe lifting and prevents unintended overloading of the hoist.

Product benefits:

- **Overload protection device:** the OLP hoists are factory-equipped with an Overload Protection device, which limits the maximum operating force that can be applied using the hand chain, ensuring safe and controlled lifting operations.
- **Enhanced safety:** each hoist undergoes dynamic proof load testing at 1.5 times the Working Load Limit (WLL) before leaving the factory, ensuring maximum safety and reliability. The hoist is equipped with a well-covered automatic load reaction brake and features double safety with two brake pawls and four brake springs, exceeding EN 13157 requirements. The load chain is calibrated, proof load tested and meets the requirements of EN 818-7.
- **Smooth and efficient operation:** the compact and lightweight construction, combined with a sprocket wheel equipped with needle bearings and a drive shaft supported by needle and slide bearings, ensures smooth and efficient operation. The fine-calibrated load chain offers quiet and seamless performance.
- **Quality load chain:** the load chain complies with the EN818-7 T(8) standard and features a Chrome 6-free electro-galvanized surface finish to protect it from corrosion.

[... Read more](#)

Material: Durable all steel construction

Marking: According to standard, CE-marked, UKCA-marked, POWERTEX, Model, WLL, Chain, Serial number, User manual/QR code

Temperature range: -10°C up to +50°C

Finish: Powder coated finish and plated frame components

Standard: EN 13157, EN 818-7

Safety factor: 4:1

Lever Hoist POWERTEX PLH-S2OLP with electrogalvanized chain

Blueprint

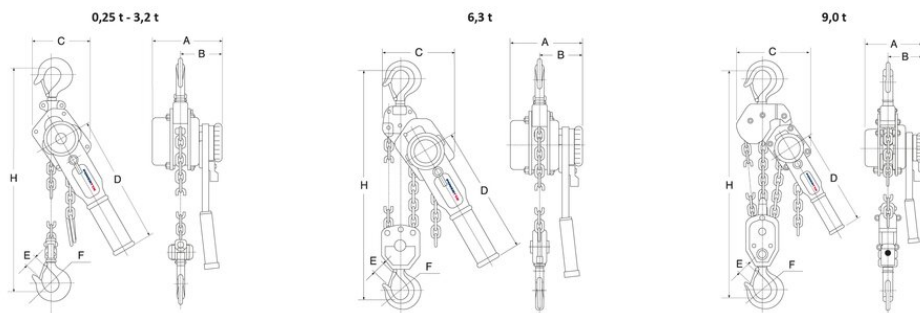

Technical data

Part code	WLL ton	Lifting height m	Number of falls	Weight kg	Model	Load chain mm	Hand force max. kg	A mm	B mm	C mm	D, mm	E mm	F mm	H min mm
500500050150891	0.5	1.5	1	5.2	PLH-S2OLP/500KG PHCA	5,0 x 15,0	24.8	150	90	118	253	22	32	310
500500050300891	0.5	3	1	6	PLH-S2OLP/500KG PHCA	5,0 x 15,0	24.8	150	90	118	253	22	32	310
500500080150891	0.8	1.5	1	6.6	PLH-S2OLP/800KG PHCA	5,6 x 17,0	26.5	158	98	132	273	26	36	340
500500080300891	0.8	3	1	7.6	PLH-S2OLP/800KG PHCA	5,6 x 17,0	26.5	158	98	132	273	26	36	340
500500080600891	0.8	6	1	9.53	PLH-S2OLP/800KG PHCA	5,6 x 17,0	26.5	158	98	132	273	26	36	340
500500160150891	1.6	1.5	1	11	PLH-S2OLP/1600KG PHCA	7,1 x 21,0	29.5	185	111	145	378	29	43	400
500500160300891	1.6	3	1	12.6	PLH-S2OLP/1600KG PHCA	7,1 x 21,0	29.5	185	111	145	378	29	43	400
500500320150891	3.2	1.5	1	19.9	PLH-S2OLP/3200KG PHCA	10,0 x 28,0	33.5	212	124	198	418	37	50	520
500500320300891	3.2	3	1	20.5	PLH-S2OLP/3200KG PHCA	10,0 x 28,0	33.5	212	124	198	418	37	50	520
500500630150891	6.3	1.5	2	24.6	PLH-S2OLP/6300KG PHCA	10,0 x 28,0	37	212	124	230	418	43	53	640
500500630300891	6.3	3	2	31.2	PLH-S2OLP/6300KG PHCA	10,0 x 28,0	37	212	124	230	418	43	53	640
500500900150891	9	1.5	3	50	PLH-S2OLP/9000KG PHCA	10,0 x 28,0	42	212	124	338	418	44	67	730
500500900300891	9	3	3	60	PLH-S2OLP/9000KG PHCA	10,0 x 28,0	42	212	124	338	418	44	67	730