

Chain Block Powertex PCB-S2 with Corolim® Chain

Product information



POWERTEX

The Powertex PCB-S2 Hoist is a high-quality chain block designed to provide durability, safety, and ease of operation. With its ergonomic hand chain and advanced features, this chain hoist ensures smooth and efficient lifting for various industrial applications.

Product benefits:

Enhanced safety: Each hoist undergoes dynamic proof load testing at 1.5 times the Working Load Limit (WLL) before leaving the factory, ensuring maximum safety and reliability. The hoist is equipped with a well-covered automatic load reaction brake and features double safety with two brake pawls and four brake springs, exceeding EN 13157 requirements. The load chain is calibrated, proof load tested and meets the requirements of EN 818-7.

Smooth and efficient operation: The compact and lightweight construction, combined with a sprocket wheel equipped with needle bearings and a drive shaft supported by needle and slide bearings, ensures smooth and efficient operation. The fine-calibrated European-made COROLIM® protected load chain offers quiet and seamless performance.

Load chain with superior corrosion resistance: The unique COROLIM® surface treatment of the load chain provides excellent corrosion protection, equivalent to ISO944-9 C5High / ISO9223 C3 standards, ensuring long-lasting durability even in harsh environments.

Easy positioning and safe hooks: Swivel hooks at both ends make in-line positioning easy. The hooks are designed to open at overload instead of breaking, enhancing safety. Heavy-duty steel safety latches and deformation check dots forged into the side of the hooks allow for easy overload detection.

Convenient maintenance and documentation: Each hoist is RFID-equipped for easy service and inspection, and a QR code provides on-site access to [multilingual user manuals, test certificates and Declaration of Conformity](#). [Read more](#)

Material: Durable all steel construction

Marking: According to standard, CE-marked, UKCA-marked, POWERTEX, Model, WLL, Chain, Serial number, User manual/QR code

Temperature range: -10°C up to +50°C

Finish: Red powder coated body and plated frame components

Standard: EN 13157, EN 818-7

Safety factor: 4:1

Chain Block Powertex PCB-S2 with Corolim® Chain

Blueprint

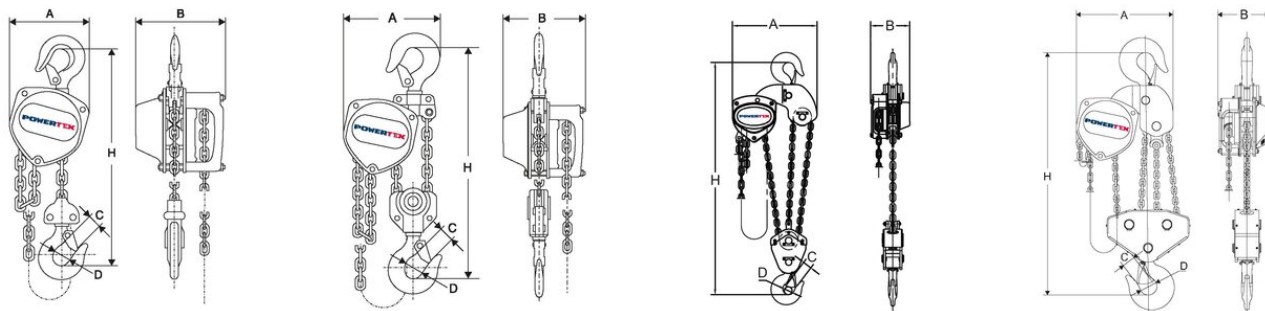

Technical data

Part code	WLL ton	Lifting height m	Number of falls	Weight kg	Model	Load chain mm	Hand chain mm	Hand force max. kg	A mm	B mm	C mm	D mm	H min mm
500100030300230	0.25	3	1	5.9	PCB-S2/250KG PHC	4,0 x 12,0	5,0 x 23,7	23.5	108	106	20	30	260
500100030600230	0.25	6	1	6.4	PCB-S2/250KG PHC	4,0 x 12,0	5,0 x 23,7	23.5	108	106	20	30	260
500100050300230	0.5	3	1	9.8	PCB-S2/500KG PHC	5,0 x 15,0	5,0 x 23,7	24.9	130	128	22	34	280
500100050600230	0.5	6	1	9.8	PCB-S2/500KG PHC	5,0 x 15,0	5,0 x 23,7	24.9	130	128	22	34	280
500100100300230	1	3	1	11.7	PCB-S2/1000KG PHC	6,3 x 19,0	5,0 x 23,7	28.4	150	145	26	39	330
500100100600230	1	6	1	12	PCB-S2/1000KG PHC	6,3 x 19,0	5,0 x 23,7	28.4	150	145	26	39	330
500100200300230	2	3	1	18.9	PCB-S2/2000KG PHC	8,0 x 24,0	5,0 x 23,7	34.3	185	175	35	49	385
500100200600230	2	6	1	19.5	PCB-S2/2000KG PHC	8,0 x 24,0	5,0 x 23,7	34.3	185	175	35	49	385
500100300300230	3	3	2	28.9	PCB-S2/3000KG PHC	7,1 x 21,0	5,0 x 23,7	34.3	220	158	37	50	510
500100300600230	3	6	2	28.9	PCB-S2/3000KG PHC	7,1 x 21,0	5,0 x 23,7	34.3	220	158	37	50	510
500100500300230	5	3	2	37.1	PCB-S2/5000KG PHC	9,0 x 27,0	5,0 x 23,7	37.2	255	183	43	60	615
500100500600230	5	6	2	51.05	PCB-S2/5000KG PHC	9,0 x 27,0	5,0 x 23,7	37.2	255	183	43	60	615